

SPW Heavy Duty Bearing Units

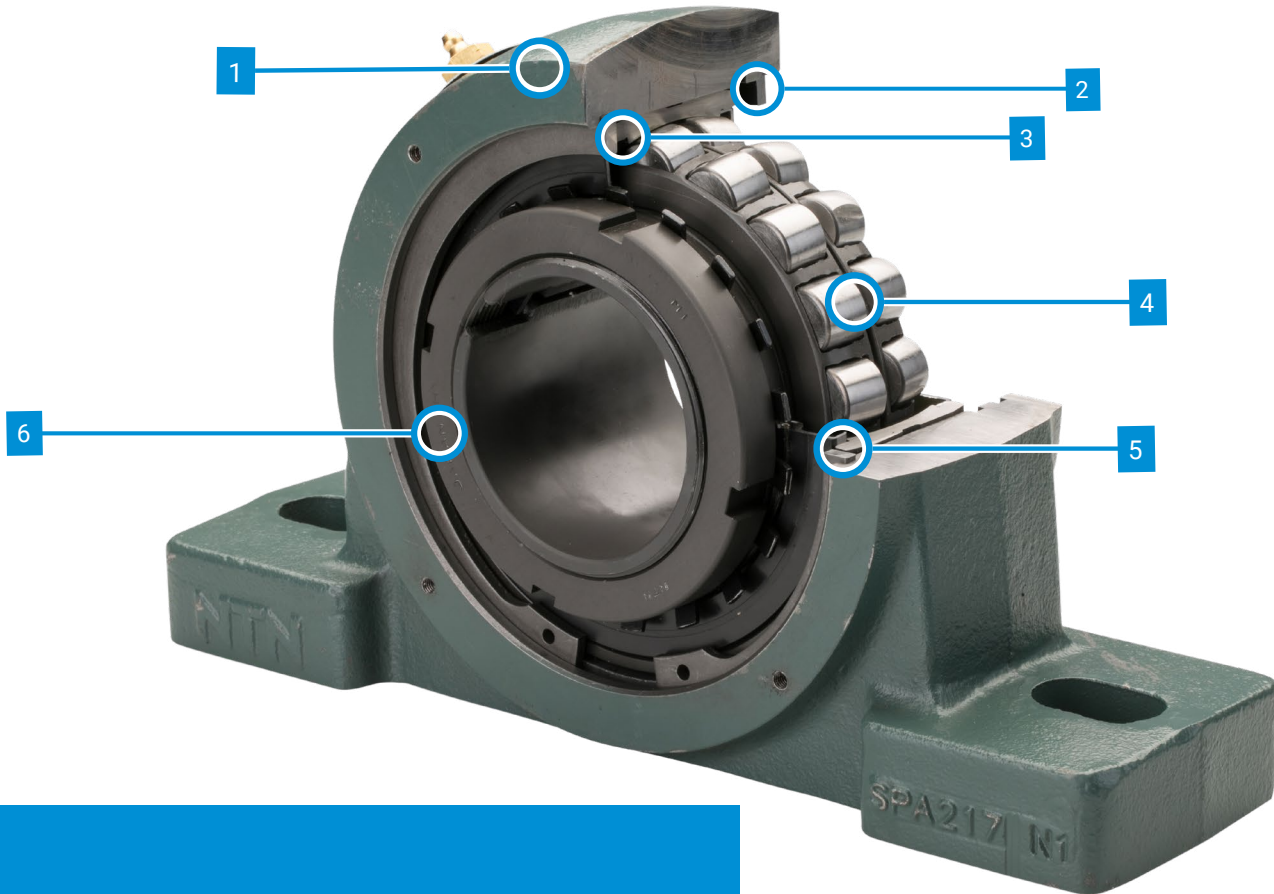

Features and benefits

1. One-piece, sturdy ductile iron housing to withstand high shock and impact from falling debris
2. Repositionable snap ring allows for versatile fixed or float unit
3. Spring-loaded, single-lip contact bearing seal for superior sealing
4. Bearings with super-finished rollers for less noise
5. Unitized bearing insert allows for easy replacement
6. Phosphate-coated locknut/adaptor sleeve for secure mounting and corrosion protection

Same Base-to-Shaft-Center Height (H) & Bolt Position (J) as SN500 Units

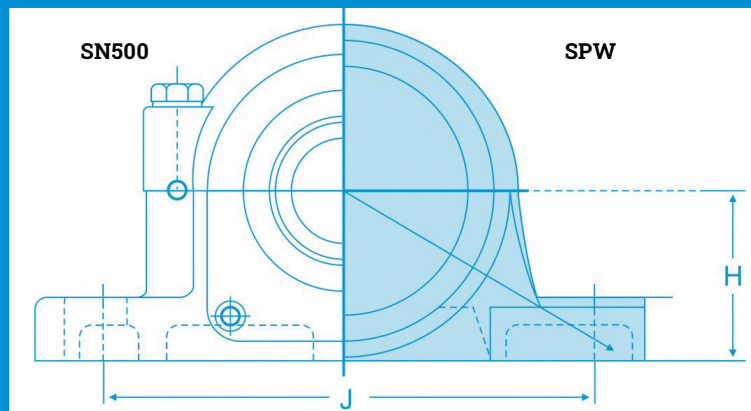

- SPW units are available with metric bore & inch bore sizes
- Metric - 50mm -140mm bore size
- Inch - 1 15/16" - 5 1/2" bore size
- SPW units available as 2-bolt and solid base

SPW/SN500 Series Interchange Guide

Shaft	NTN SPW	SN500 Series
Attachment	Adapter Mount	Adapter Mount
50	SPAW2211-N1	SN511
60	SPAW2213-N1	SN513
65	SPAW2215-N1	SN515
75	SPAW2217-N1	SN517
90	SPAW2220-N1	SN520
100	SPAW2222-N1	SN522
110	SPAW2224-N1	SN524
115	SPAW2226-N1	SN526
125	SPAW2228-N1	SN528
140	SPAW2232-N1	SN532

NTN SPW options available:

C prefix - two covers with taconite service seals

CM prefix - one cover with taconite service seal, one end cover

SPW



4 Components

SN500 Series



12 Components

Optional SPW with End Covers

